

Table of Contents

| | | |
|------------------|-------------------------------------------------|-----------|
| Section 1 | Components/Specifications..... | 3 |
| Section 2 | Maintenance..... | 5 |
| Section 3 | Expansion/Contraction..... | 6 |
| Section 4 | Recommended Stake Pocket Spacing.. | 6 |
| Section 5 | Assembly: Stacking Forms..... | 7 |
| Section 6 | Assembly: Straight Work..... | 9 |
| 6.1 | Flatwork..... | 9 |
| 6.2 | Curb Only..... | 10 |
| 6.3 | Curb & Gutter..... | 11 |
| Section 7 | Assembly: Radius Work..... | 13 |
| 7.1 | Introduction: "Stake as you go"..... | 13 |
| 7.2 | Flatwork..... | 14 |
| 7.3 | Curb Only..... | 15 |
| 7.4 | Curb & Gutter..... | 16 |
| Section 8 | Curb & Gutter Bill of Materials..... | 17 |

POLY FORMS

MATERIAL

High Density Polyethylene (HDPE)

HEIGHT

4" and 6"

LENGTH

12"

WEIGHT

4" Flexible, 0.5 lbs. per foot
 4" Straight, 1.0 lbs. per foot
 6" Flexible, 0.75 lbs. per foot
 6" Straight, 1.25 lbs. per foot

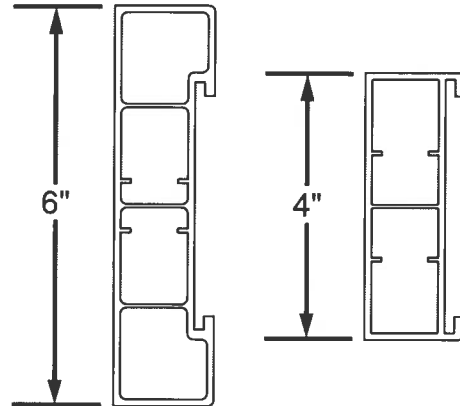

10 Forms Per Box

| | |
|-------------|------------------|
| 4" Flexible | 77 lbs. per box |
| 4" Straight | 129 lbs. per box |
| 6" Flexible | 105 lbs. per box |
| 6" Straight | 155 lbs. per box |

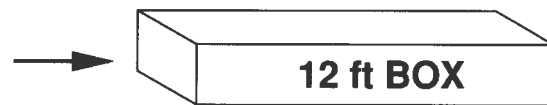

META STAKE POCKETS

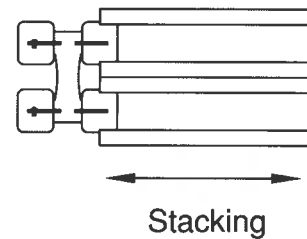
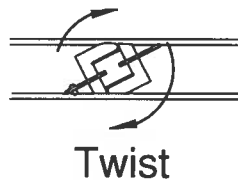
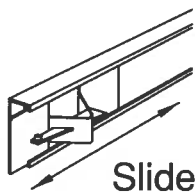

MATERIAL

Special Analysis Steel

WEIGHT

| | |
|----------|---------------------|
| Slide | 1.3 lbs. per pocket |
| Twist | 1.3 lbs. per pocket |
| Stacking | 3.0 lbs. per pocket |



- 15 Slide pockets per bucket (23 lbs)
- 30 Twist pockets per bucket (42 lbs)
- 5 Stacking pockets per bucket (17 lbs)

RECOMMENDED QUANTITIES: 4" & 6" Forms/Straight & Flexible

Per 12' length: 4 Pockets

1-Slide Pocket
 3-Twist Pockets

Per Box: 2 Buckets

1-Slide Bucket
 1-Twist Bucket

1.0 Components/Specifications

OVERHEAD HANGER UNITS

MATERIAL

Special analysis steel

WEIGHT

3.75 lbs per unit; 21 lbs. per bucket

PACKAGE

5 pairs per bucket

SETTINGS/ADJUSTABILITY

Width: 4-1/2" to 7" wide curb.

Layback/Batter: 0, 1/2, 1, 1-1/2, 2"

(No batter on radius set-ups)

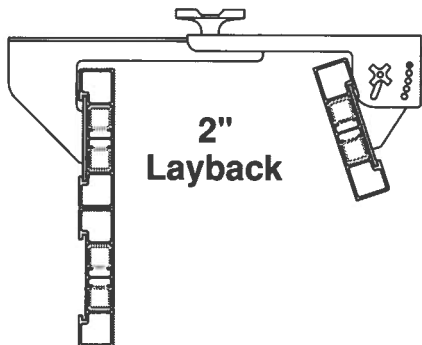
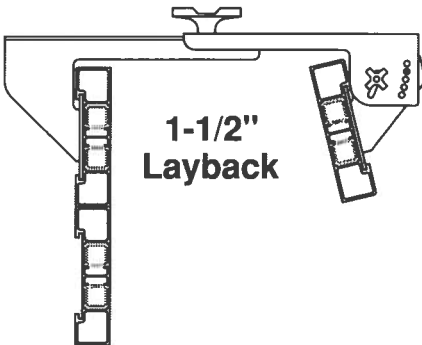
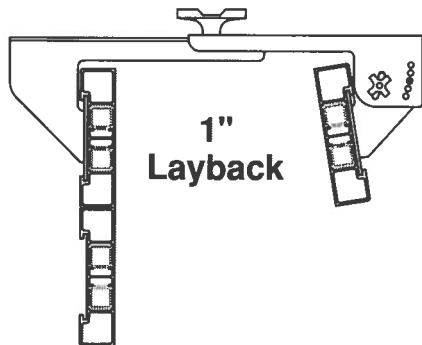
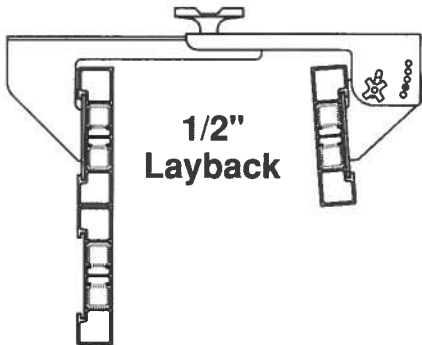
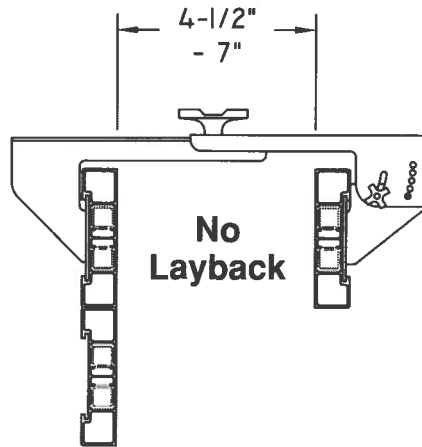
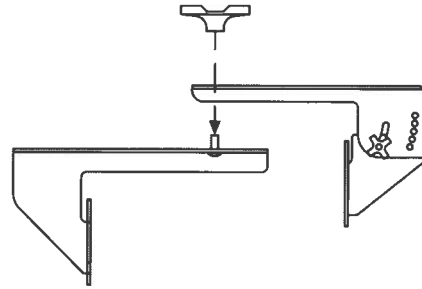

Keep all components clean before and after use.

THE USE OF A RELEASE AGENT IS RECOMMENDED TO HELP KEEP THE FORMS AND POCKETS FREE OF DEBRIS.

6-inch form shown

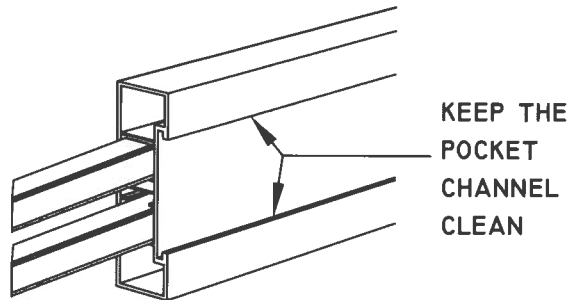

Slide pockets may be used to clean channels.

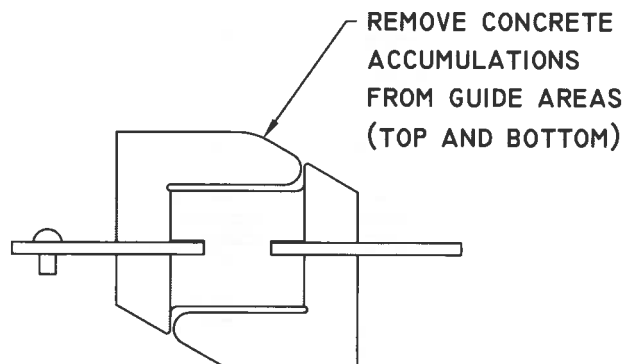
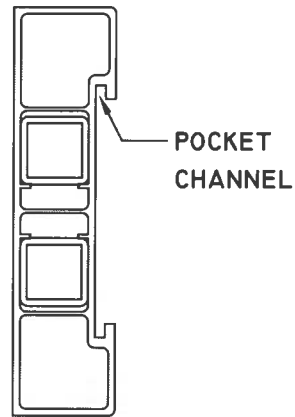
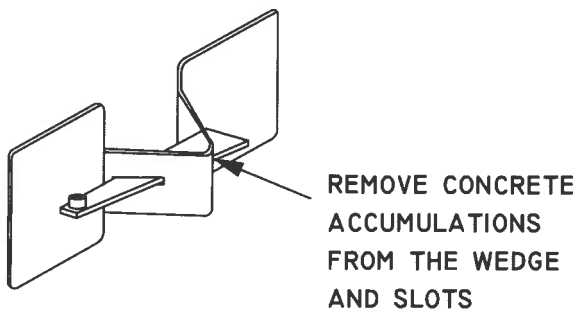

3.0 Expansion/Contraction

Poly forms: temperature will affect the overall length. At 80 degrees Fahrenheit it is typical for a form to measure 12'-1/2" long. At 40 degrees Fahrenheit it may measure 11'-11-3/4" long. Remember to take this into consideration when setting forms.

If a gap appears between the forms, it can be easily closed by tapping from the end of the form.

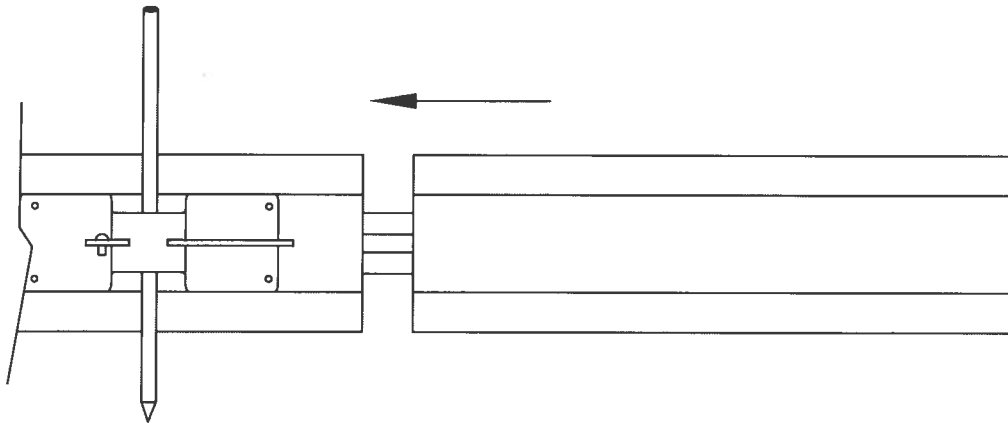

4.0 Recommended Stake Pocket Spacing

Note: End pockets are shared with the next form.

1) A single form with slide pocket on zone ends and twist pockets every 3 feet.

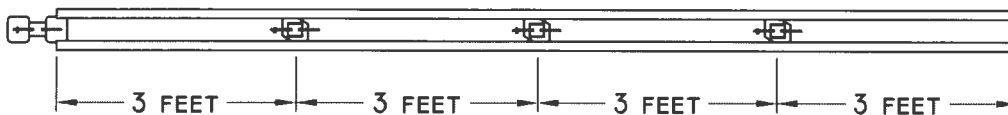

2) Stacking two forms together using pockets every 3 feet.

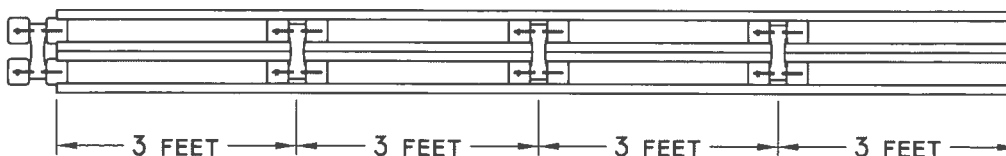

Assembly: Stacking Forms 5.0

Forms can be stacked using stacking pockets:

| RECOMMENDED STAKE LENGTHS | |
|---------------------------|------------------|
| Stacking Height of Forms | Use Stake or Pin |
| 8" (4+4) | 24" |
| 10" (4+6) | 30" |
| 12" (6+6) | 36" |

Pockets slide in from end of forms.

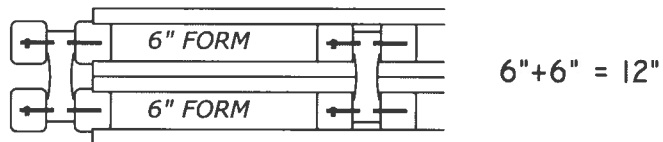
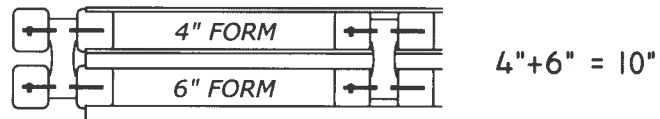
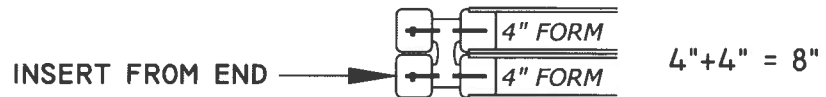

Step 1: Set forms together

Set forms side-by-side on a flat surface, with the channel facing up.

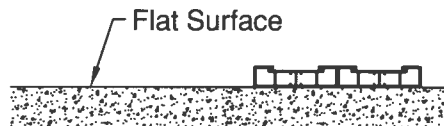
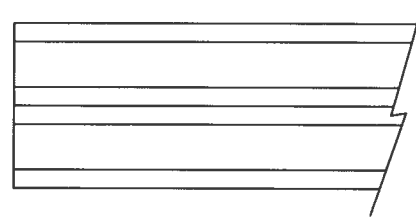

Align the ends of the forms.

Step 2: Connect forms together

Slide in stacking pocket.

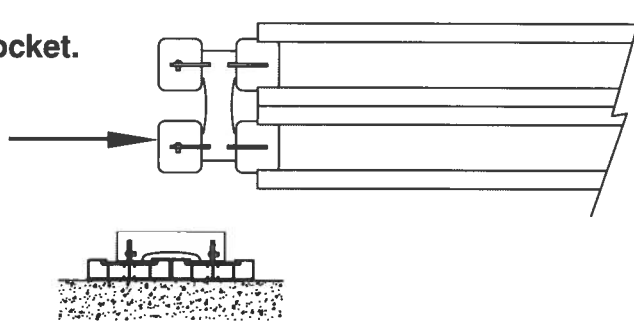

5.0 Assembly: Stacking Forms

Step 3: Slide in additional pockets

Slide pockets down the channel, using your hands or feet, by pushing on the center (as shown by arrow). Typical pocket spacing is three (3) feet.

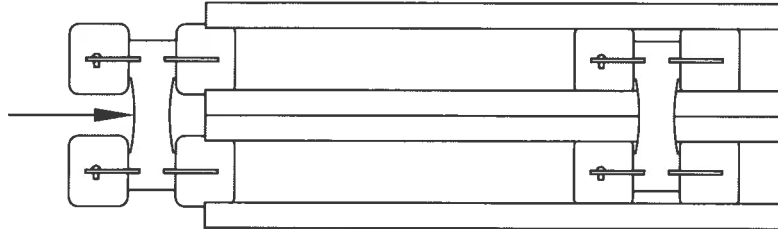

Step 4: Set form(s) in place

With pockets installed, set form(s) upright.

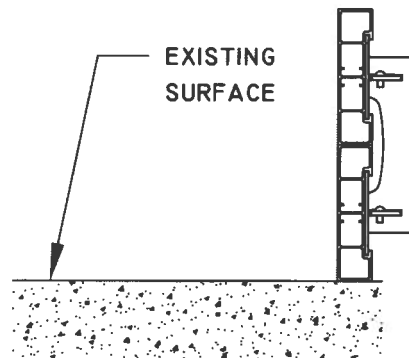

Step 5: Install stakes (pins)

Install the stakes into the ground, and lock the wedges onto the stakes. It is recommended to use stakes that are either 3/4 inch or 7/8 inch in diameter. (Stake should penetrate at least 12" into the ground.)

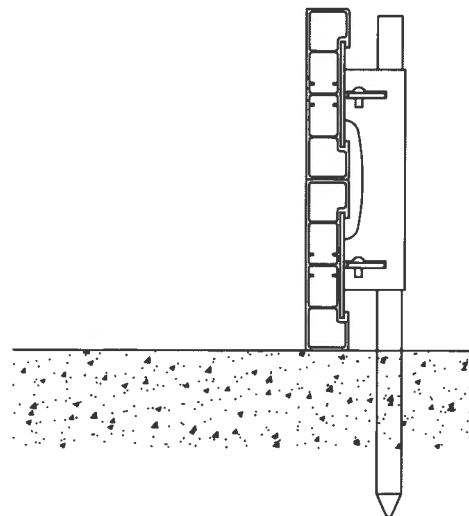

Assembly: Straight Work 6.0

Section 6 contains the following sub-sections:

- 6.1 Flatwork
- 6.2 Curb Only
- 6.3 Curb & Gutter

Assembly: Straight Work - Flatwork 6.1

Step 1: Slide pockets: slide into form from either end.

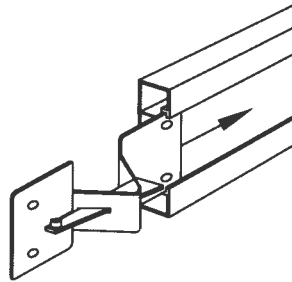

Step 2: Add twist pockets anywhere along the form where additional support is required. *Note: recommend 3 foot spacing.*

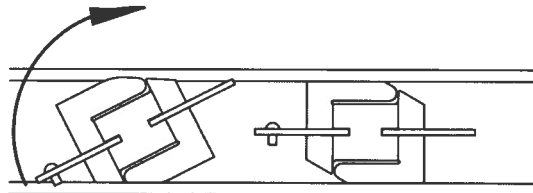

Step 3: Join forms together using end connection as a guide.

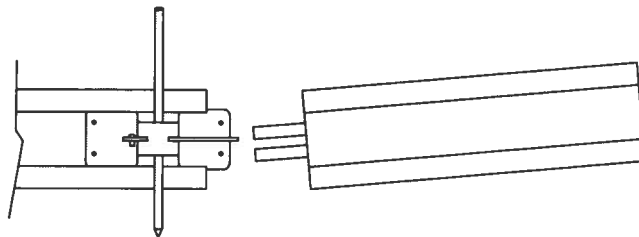

6.2 Assembly: Straight Work - Curb Only

Step 1: Stack per assembly instructions for stacking forms.

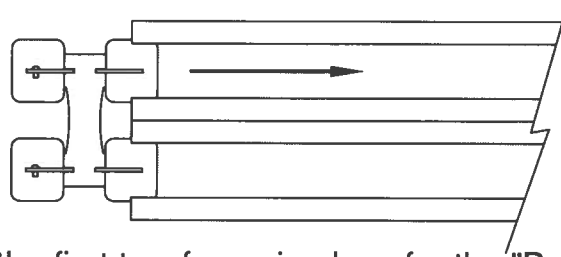

Step 2: Set the first two forms in place for the "Back" of the curb. Drive the stakes through the pockets.

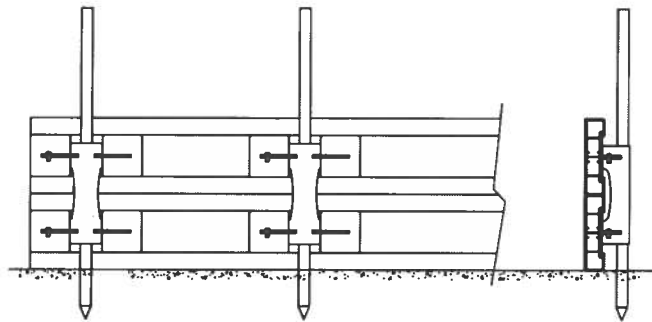

Step 3: When stacking more than two forms, place the third form on top with slide pockets already installed in form.

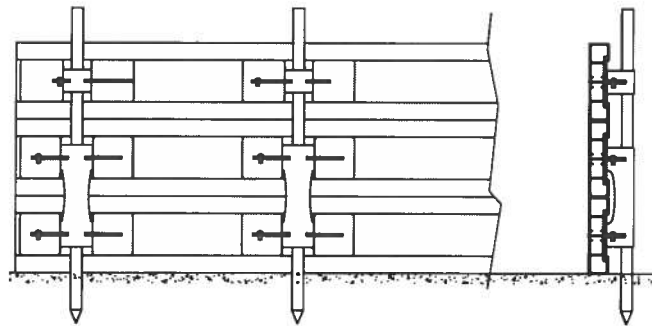

Step 4: For vertical curb or partially battered curb, use overhead hangers. (5 per 12' setup)

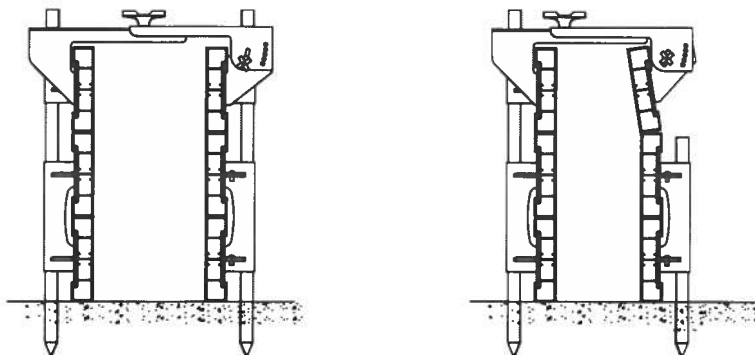

Assembly: Straight Work - Curb & Gutter 6.3

Step 1: Set the first two forms in place for the "Back" of the curb. Drive the stakes through the pockets

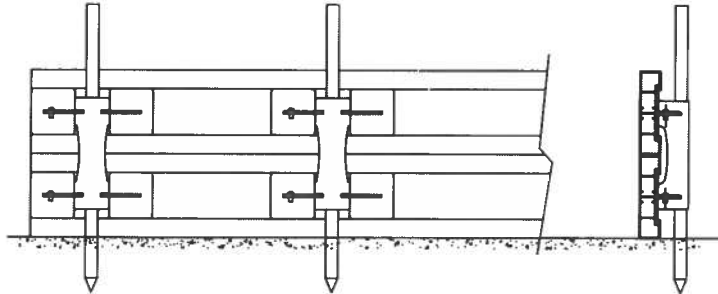

Step 2: Set the "front" form at the specified location; twist a hanger into the "back" form.

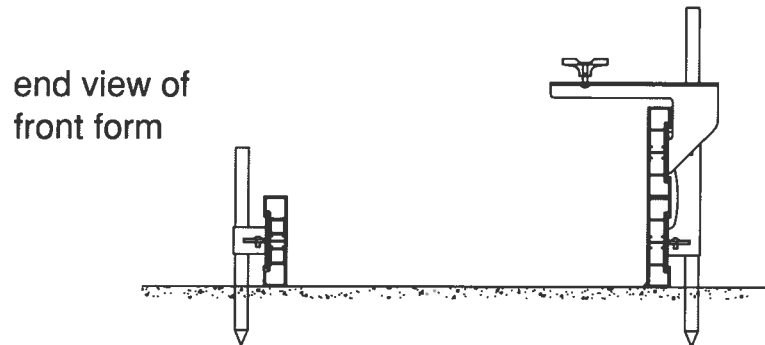

Step 3: Back view: twist-in overhead hanger. Locate the hanger close to a "pocket" for extra support.

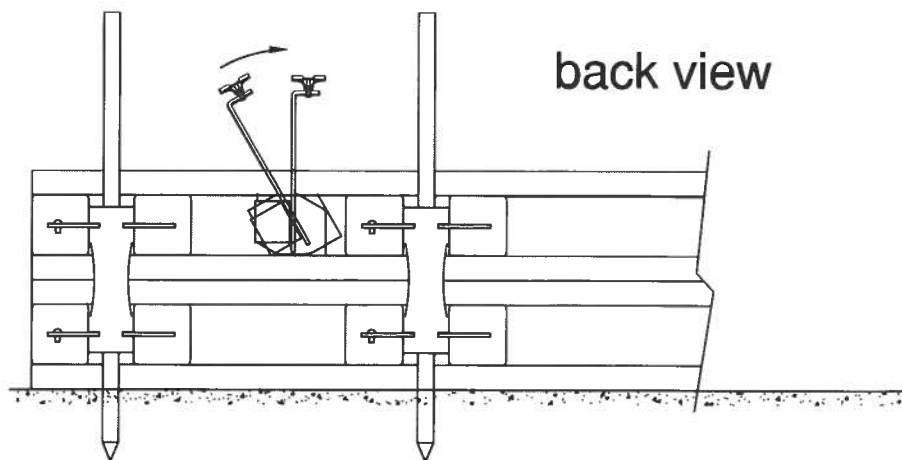

6.3 Assembly: Straight Work - Curb & Gutter

Step 4: Install hanger into the "face" form. Bring the "face" into position to match up the slots with the clamp pins. Adjust curb thickness. Tighten the clamps.

NOTE: Overhead hangers adjust for curbs between 4-1/2 and 7" thick.

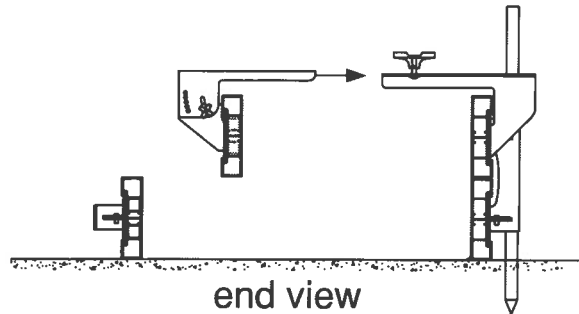

Forming 8" curb face: set face with stacking pockets and stakes.

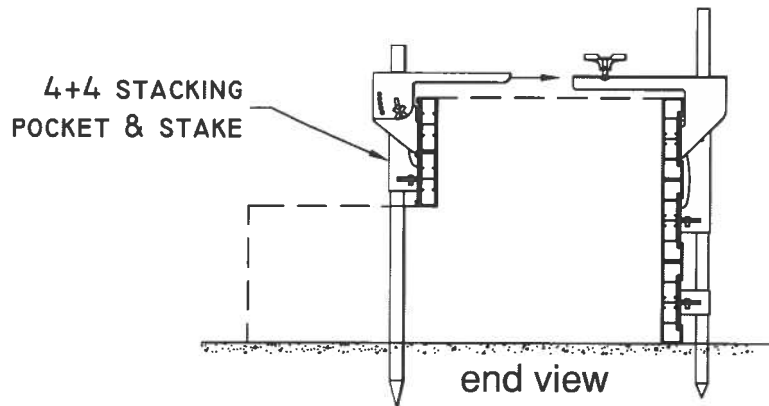

Step 5: Complete Setup: Five (5) overhead hangers per 12-foot set-up.

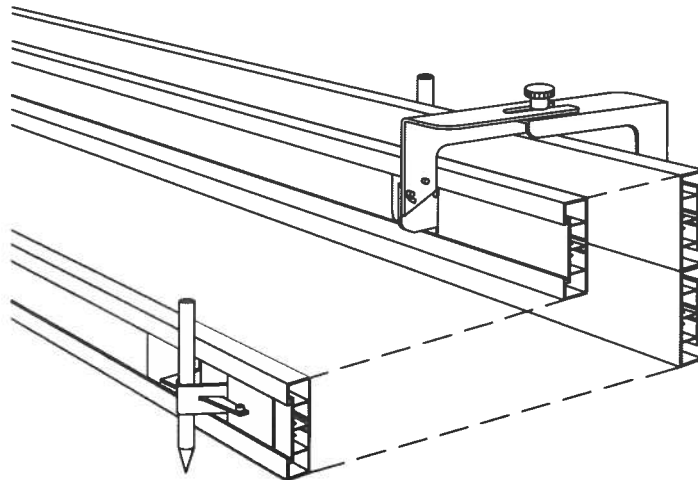

7.0 Assembly: Radius Work

Section 7 contains the following sub-sections:

- 7.1 Introduction: "Stake as you go"
- 7.2 Flatwork
- 7.3 Curb Only
- 7.4 Curb & Gutter

7.1 Introduction: "Stake as you go"

Plan Ahead: "Stake as you go": Bend the form around the radius, staking as you go.

- Joints between forms should not be at the apex of a radius.
- Join forms together using end connection as a guide.
- Use form pins as guides, to bend form around radius.

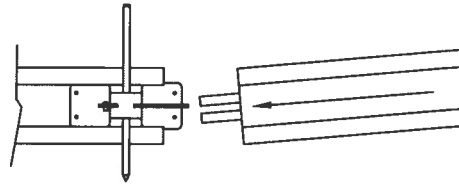

Step 1: Trace radius onto ground or set stringline. (Example shown below: forming a 4' outside radius, overhead view.)

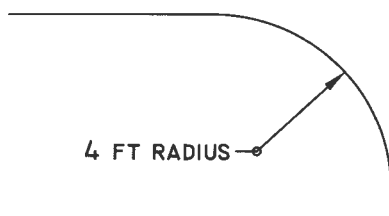

Step 2: Set stakes as "guide pins" along arc.

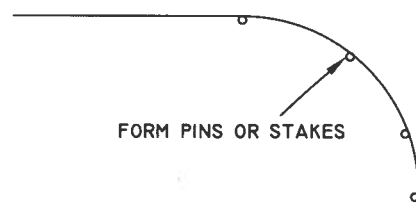

Step 3: Set form in place, starting at one end; stake into place (about every 3 ft.); lock the wedges.

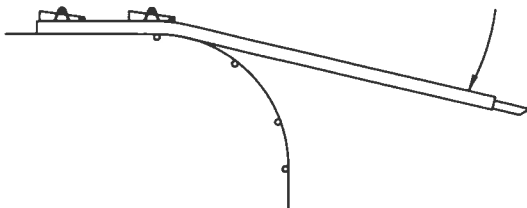

Step 4: Join forms together using end connection as a guide.

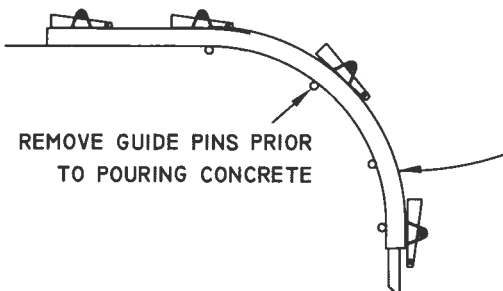

7.2 Assembly: Radius Work - Flatwork

| RECOMMENDED FORMS | | |
|-------------------|-------------------|-----------------------------------------------------------------------------|
| Height of Form | Radius | Type of Form |
| 4" or 6" | 3' min. to 30' | Flexible forms with <u>yellow</u> end connections. |
| | 30' to 70' | Flexible forms with <u>yellow</u> end connections and black radius inserts. |
| 6" | 70' + | Straight form with <u>silver</u> aluminum end connection/inserts. |

| RECOMMENDED STAKES | |
|--------------------|----------------------------------|
| Height of Form | Stake or Pin (3/4" or 7/8" dia.) |
| 4" | 18" |
| 6" | 24" |

Overhead views shown below: Flatwork forms (4" & 6")

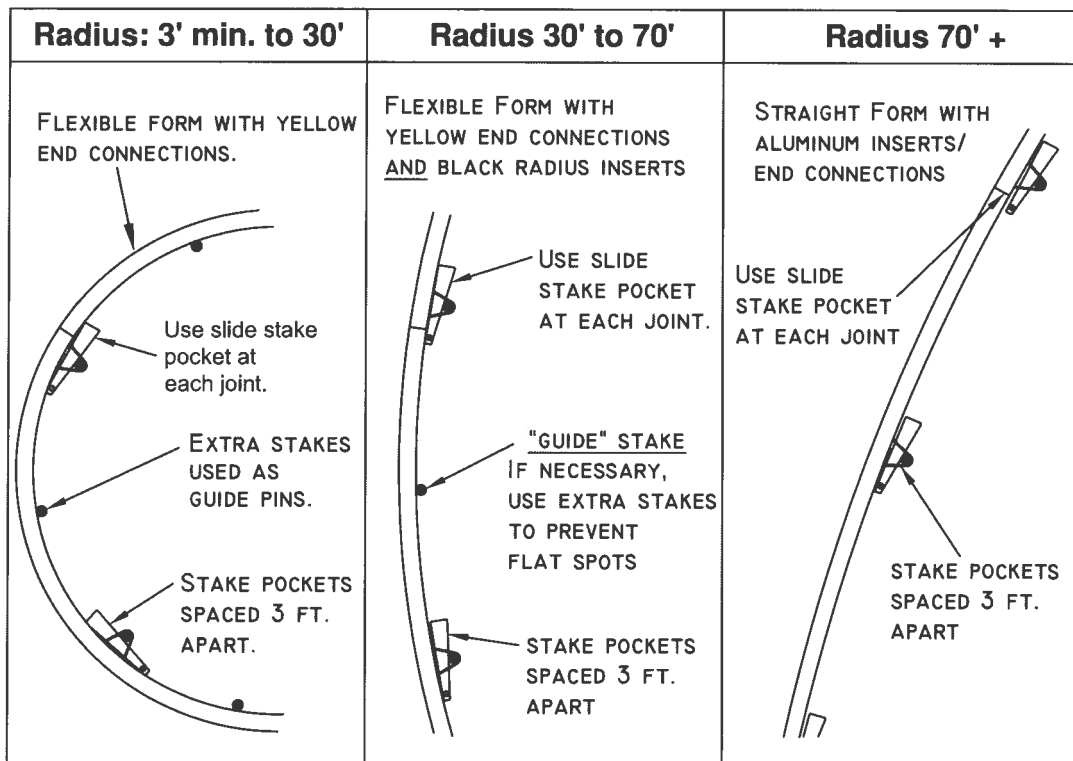

Assembly: Radius Work - Curb Only 7.3

| RECOMMENDED FORMS | | |
|---------------------------------------------------------------|----------------|-----------------------------------------------------------------------------|
| Height of Form | Radius | Type of Form |
| 8" high, 4"+4" stacking pocket | 3' min. to 30' | Flexible forms with <u>yellow</u> end connections. |
| 10" high, 4"+6" stacking pocket | | |
| 12" high, 6"+6" stacking pocket | 30' to 70' | Flexible forms with <u>yellow</u> end connections and black radius inserts. |
| 18" high, 6"+6"+6" stacking pocket plus twist or slide pocket | 70' + | Straight form with <u>silver</u> aluminum end connection/ inserts. |

| RECOMMENDED STAKES | |
|--------------------|----------------------------------|
| Height of Form | Stake or Pin (3/4" or 7/8" dia.) |
| 8" | 24" |
| 10" | 30" |
| 12" | 36" |
| 18" | 36" |

| RECOMMENDED ACCESSORIES | |
|-------------------------|-----------|
| Overhead Hangers | Every 30" |

Vertical face radius curb (side view)

Vertical face radius curb (top view)

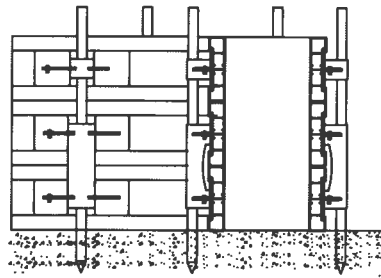
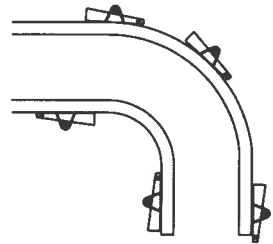

Overhead views shown below: Curb only (up to 18")

| Radius: 6' min. to 30' | Radius 30' to 70' | Radius 70' + |
|--------------------------------------------------------------------------------------------------------------------------------------------------------------------------------------------------------------------------------------------------------------------------------------------------|-----------------------------------------------------------------------------------------------------------------------------------------------------------------------------------------------------------------------------------------------------------------------------------------------------------------------------------------------------------|--------------------------------------------------------------------------------------------------------------------------------------------------------------------------------------------------------------------------------------|
| <p style="text-align: center;">FLEXIBLE FORM WITH YELLOW END CONNECTIONS.</p> <p style="text-align: center;">Use slide stake pocket at each joint.</p> <p style="text-align: center;">EXTRA STAKES USED AS GUIDE PINS.</p> <p style="text-align: center;">STAKE POCKETS SPACED 30 IN. APART.</p> | <p style="text-align: center;">FLEXIBLE FORM WITH YELLOW END CONNECTIONS AND BLACK RADIUS INSERTS</p> <p style="text-align: center;">USE SLIDE STAKE POCKET AT EACH JOINT.</p> <p style="text-align: center;">"GUIDE" STAKE IF NECESSARY, USE EXTRA STAKES TO PREVENT FLAT SPOTS</p> <p style="text-align: center;">STAKE POCKETS SPACED 30 IN. APART</p> | <p style="text-align: center;">STRAIGHT FORM WITH ALUMINUM INSERTS/ END CONNECTIONS</p> <p style="text-align: center;">USE SLIDE STAKE POCKET AT EACH JOINT</p> <p style="text-align: center;">STAKE POCKETS SPACED 30 IN. APART</p> |

| RECOMMENDED FORMS | | |
|---------------------------------------------------------------|----------------|---------------------------------------------------------------------------------------------------------------------------------|
| Height of Form | Radius | Type of Form |
| 8" high, 4"+4" stacking pocket | 6' min. to 30' | Flexible forms with <u>yellow end connections</u> . Flexible forms with <u>yellow end connections</u> and black radius inserts. |
| 10" high, 4"+6" stacking pocket | | |
| 12" high, 6"+6" stacking pocket | 30' to 70' | Straight form with <u>silver aluminum end connection/ inserts</u> . |
| 18" high, 6"+6"+6" stacking pocket plus twist or slide pocket | | |
| | 70' + | |

| RECOMMENDED STAKES | |
|--------------------|----------------------------------|
| Height of Form | Stake or Pin (3/4" or 7/8" dia.) |
| 8" | 24" |
| 10" | 30" |
| 12" | 36" |
| 18" | 36" |

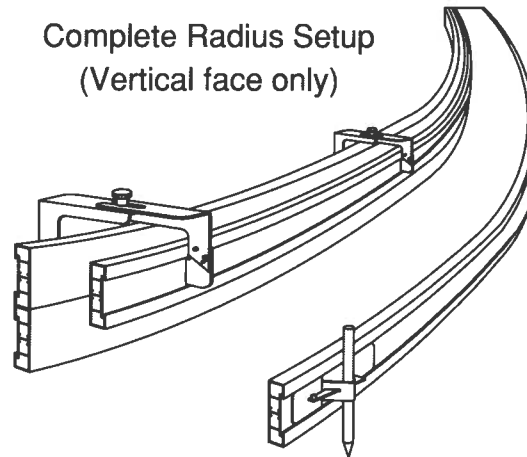

| RECOMMENDED ACCESSORIES | |
|-------------------------|-----------|
| Overhead Hangers | Every 30" |

Overhead views shown below: Curb & Gutter (Vertical face only)

| Radius: 6' min. to 30' | Radius 30' to 70' | Radius 70' + |
|---------------------------------------------------------------------------------------------------------------------------------------------------------------------------------------------------------------------|---------------------------------------------------------------------------------------------------------------------------------------------------------------------------------------------------|-------------------------------------------------------------------------------------------------------------------------------------------------------------------------------------|
| <p>FLEXIBLE FORM WITH YELLOW END CONNECTIONS.</p> <p>Use slide stake pocket at each joint.</p> <p>OVERHEAD HANGER (30" SPACING)</p> <p>EXTRA STAKES PREVENTS FLAT SPOTS.</p> <p>STAKE POCKETS SPACED 30" APART.</p> | <p>FLEXIBLE FORM WITH YELLOW END CONNECTIONS AND BLACK RADIUS INSERTS</p> <p>USE SLIDE STAKE POCKET AT EACH JOINT.</p> <p>OVERHEAD HANGER (30" SPACING)</p> <p>STAKE POCKETS SPACED 30" APART</p> | <p>STRAIGHT FORM WITH ALUMINUM INSERTS/ END CONNECTIONS</p> <p>USE SLIDE STAKE POCKET AT EACH JOINT.</p> <p>OVERHEAD HANGER (30" SPACING)</p> <p>STAKE POCKETS SPACED 30" APART</p> |

8.0 Curb & Gutter Bill of Materials

SETUP FOR STRAIGHT OR RADIUS
Overhead Hanger - with Poly Face

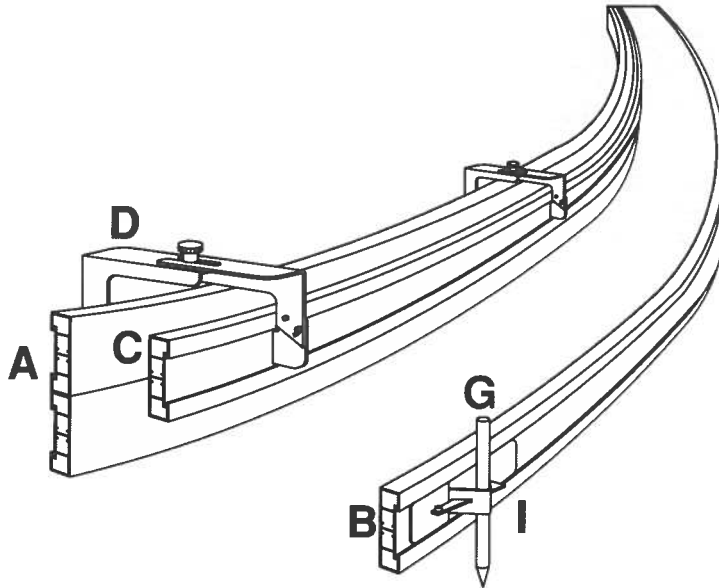

| ITEM | DESCRIPTION | RECOMMENDED QUANTITIES |
|------|----------------------------------------------------------------------------------------------------------|----------------------------------------------------|
| A | Back Curb Form, 12" Poly (requires (2) 6" Poly forms stacked on top of each other) 6" Poly Form | (2) |
| B | Front Gutter Form, 6" Poly | (1) |
| C | Curb Face Form, 6" Poly | (1) |
| D | Overhead Hanger Unit | (5) |
| E | *Twist Stake Pocket | (3) |
| F | *Nail Stake (3/4 x 30) | (5) |
| G | Nail Stake (3/4 x 18) | (4) |
| H | *Stacking Pocket (6"+6") | (5) |
| I | Slide Pocket | (1) |
| | *Items Not Shown | Note: a total of (4) 6" Poly Forms are required |